

Development of a Backpack-Based Wearable Proximity Detection System

Hyungsub Shin¹⁾, Seokhee Chang²⁾, Namgyenong Yu³⁾, Chaeun Jeong⁴⁾, Wen Xi⁴⁾, and Jihyun Bae^{1)†}

¹⁾Human-Tech Convergence Program, Department of Clothing & Textiles, Hanyang University; Seoul, Korea

²⁾Dept. of Textiles, Merchandising & Fashion Design, Seoul National University; Seoul, Korea

³⁾Nobrand; Seoul, Korea

⁴⁾Dept. of Clothing & Textiles, Hanyang University; Seoul, Korea

Abstract: Wearable devices come in a variety of shapes and sizes in numerous fields and are available in various forms. They can be integrated into clothing, gloves, hats, glasses, and bags and used in healthcare, the medical field, and machine interfaces. These devices keep track individuals' biological and behavioral data to help with health communication and are often used for injury prevention. Those with hearing loss or impaired vision find it more difficult to recognize an approaching person or object; these sensing devices are particularly useful for such individuals, as they assist them with injury prevention by alerting them to the presence of people or objects in their immediate vicinity. Despite these obvious preventive benefits to developing Internet of Things based devices for the disabled, the development of these devices has been sluggish thus far. In particular, when compared with people without disabilities, people with hearing impairment have a much higher probability of averting danger when they are able to notice it in advance. However, research and development remain severely underfunded. In this study, we incorporated a wearable detection system, which uses an infrared proximity sensor, into a backpack. This system helps its users recognize when someone is approaching from behind through visual and tactile notification, even if they have difficulty hearing or seeing the objects in their surroundings. Furthermore, this backpack could help prevent accidents for all users, particularly those with visual or hearing impairments.

Key words: wearable device, proximity sensor, LED, vibration motor, Arduino

1. Introduction

Wearable devices find applications in diverse fields and are available in various forms like clothing, gloves, hats, glasses, and bags. They are used in health care applications, medical purposes, and also as safety and protection (Awolusi et al., 2018; Cho et al., 2008; Haghi et al., 2017; Lee & Lee, 2020). They allow the monitoring of individual biological and behavioral data for health communication (Song et al., 2020). Various sensors are often used to detect environmental conditions, which include temperature, sound, light, and surrounding objects, and to prevent physical injuries in day-to-day life (Sim et al., 2019; Sohn et al., 2017). Park et al. (2019) introduced a vehicle indoor environment detection system with a camera and a passive infrared (PIR) sensor to prevent accidents in school vehicles for children (Park et al., 2019). Ko (2017) introduced a smart safety hat with sound and light sensors

for elderly pedestrians.

Research has also been conducted to perform tasks such as real-time translation and alert management, based on wearable technology for people with hearing difficulties (Alkhalifa & Al-Razgan, 2018). This technology is not commercially available yet, and it may not be widely affordable. Furthermore, wearable terminal devices that can detect surrounding sounds in real time and convert them into visual and tactile data have been developed. Such devices are aimed at informing deaf people of the type and direction of sounds to help them cope with potentially dangerous situations (Jeon et al., 2019; Park et al., 2006). However, a sound detection system could not be sufficient to cope with all the risky scenarios that one may have to face. For instance, people with hearing loss have greater difficulty recognizing someone approaching and can feel vulnerable in crowded areas. Moreover, an inconsistent approach can cause dangerous incidents, such as bumping into someone. Additionally, they are a high-risk group for accidents on the street because of their slow risk recognition and reaction. It is thus crucial to detect approaching objects and alarm the users in advance. Developing devices that function with alarm systems, such as assistive devices, is therefore required. Various types of sensing technologies to prevent injuries to physically weak people while functioning as alarm systems to protect people with physical,

†Corresponding author: Jihyun Bae

Tel. +82-02-2220-1194

E-mail: jbae2@hanyang.ac.kr

©2022 Fashion and Textile Research Journal (FTRJ). This is an open access journal. Articles are distributed under the terms of the Creative Commons Attribution Non-Commercial License (<http://creativecommons.org/licenses/by-nc/4.0>), which permits unrestricted use, distribution, and reproduction in any medium, provided the original work is properly cited.

visual, or hearing impairments need to be developed.

In this study, we developed backpack-based wearable detection system based on an infrared (IR) proximity sensor. A vibration motor alerts users when the proximity sensor detects an approaching person or an object within a certain distance range. In addition, the system provides a warning message to the approaching person via LED lights and warns them to be aware of their proximity to the user. This backpack system helps users recognize people or objects approaching from behind through visual and tactile notifications, even if the user has difficulty in hearing or seeing the surrounding objects. Furthermore, this device can play an important role in preventing accidents among general users and people with impairments.

2. Proximity Sensor

Proximity sensors can detect objects or people without physical contact and are widely utilized in industrial applications and consumer devices for object detection, positioning, and security. Numerous proximity sensors, such as ultrasonic, infrared, and capacitive, are commercially available and designed for specific applications and conditions. Ultrasonic sensors emit a 40 kHz of sonic wave and determine the distance by measuring the signal return time after being reflected from an object. They are not affected by the object color, transparency, and external environmental conditions (Taghipour, 2017). Several studies have been conducted on the use of ultrasonic sensors as detection systems for visual- and hearing-impaired individuals (Choi et al., 2016; Ko & Kim, 2020). Similar to ultrasonic sensors, IR sensors detect the distance of an object by measuring the angle of the returning beam of infrared light after the object reflects it. Unlike ultrasound proximity sensors, IR sensors can measure the distance to soft objects. Nevertheless, the measurement accuracy remains low under certain conditions, for example, poor lighting or the presence of transparent obstacles such as windows (Ercan & Mohammed, 2020). In the case of PIR sensors, they can detect moving objects by constantly

capturing IR rays, their detection range is larger than that of IR sensors. Despite the limitation in detecting angles, they have been used in diverse wearable sensing devices owing to their substantially low cost and small size (Kratz & Rohs, 2009; McIntosh et al., 2017). There are various types of IR proximity sensors with detectable distance ranges. In this study, a sharp IR sensor (GP2Y0A02YK0F) was used as the proximity sensor, and we evaluated the changes in the electrical signal at different distances. The usable range of the sensor is 20–150 cm, and when the object is within 45 cm, an array of LEDs and two vibration motors are activated in the alarm system. We have chosen 45 cm as the proximal distance, because, at this distance, people tend to feel that the person or object is in close proximity.

3. Experimental section

Table 1 lists the specifications of the electric components used to develop the smart backpack detection system. We mounted each device on the backpack. The IR proximity sensor is the input interface and light-emitting diodes (LEDs) and vibration motors are the output interfaces. The Lilypad Arduino controller is advantageous to use in e-textiles and wearable projects, as it can be sewn to fabric and connected with sensors, actuators, and power sources with a conductive thread. To program the Lilypad Arduino mainboard in our system, we used Arduino IDE(Integrated Development Environment) Software and connected LEDs and vibration motors for e-textile electronics on the backpack.

Fig. 1 illustrates the operating procedure of the smart backpack detection system. When the proximity sensor detects people within 45 cm, the output devices of the vibration motors and an array of LEDs are activated. This detection system alerts the wearer through vibration motors attached to the bag strap. Simultaneously, the system provides a warning message for approaching people to be aware of their proximity to the wearer via the LEDs. The battery capacity of three batteries connected in series is 1,200 mA at 4.5 V, and the total current consumption of the LEDs and motors is 0.543

Table 1. Material specifications

No	Components	Specifications
(1)	Vibration motor	Lilypad Vibe Board DEV-11008, diameter: 20 mm, 75 mA
(2)	IR Proximity Sensor	Sharp - GP2Y0A02YK0F, Usable range: 20–150 cm, 4.5–5.5 V, 30 mA
(3)	LED	Lilypad LED DEV-10044, dimension: 5 mm × 11 mm
(4)	Controller	Lilypad Arduino 328 Mainboard, 3.3 V
(5)	Boost Module	Lilypad LiPower Boost Module, 5 V
(6)	Power	AAA Battery 1.5 V
(7)	Conductive yarn	Stainless steel, diameter: 0.12 mm, 27 Ω/m
(8)	Backpack	JANSPORT Half Print Bag

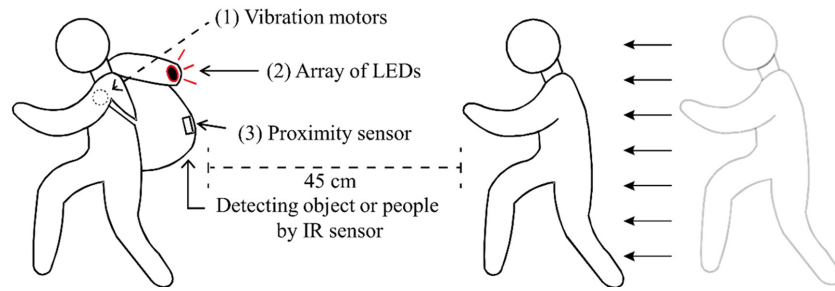

Fig. 1. Operating procedure of the smart backpack detection system.

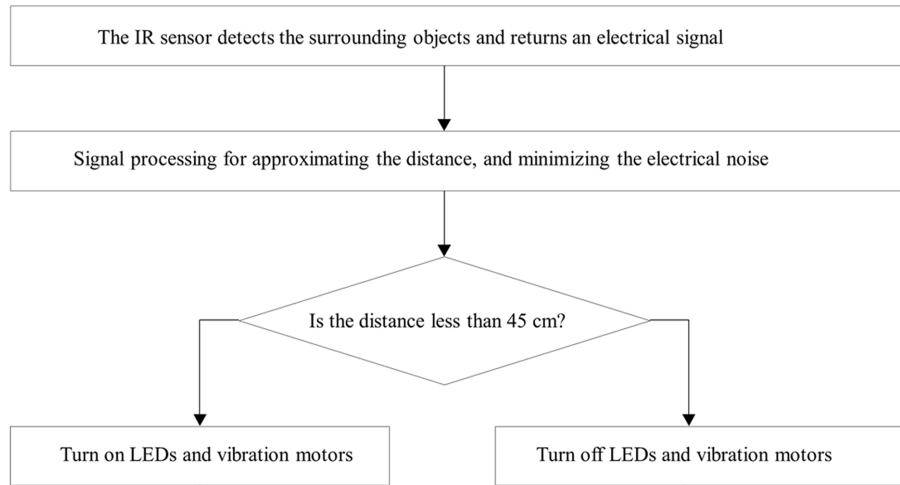

Fig. 2. Flowchart for the signal processing.

A. The operating time of the system would be 2.2 h when all the devices of the LED and vibration motor are on continuously. The actual running time would be longer as the LEDs and vibration motors are on intermittently while detecting an obstacle.

4. Results and Discussion

4.1. IR Proximity Sensors

We investigated two types of IR proximity sensors, sensor A (GP2Y0A21YK0F, SHARP) and sensor B (GP2Y0A02YK0F, SHARP), which have different usable ranges. Figure 3(a) shows the detection range measurement setup for evaluating the sensor. The black lines in Fig. 3(b) and (c) are the raw signals of each sensor A and B containing noise, which could be coming from the power supply, control circuits, or cables. To remove unwanted noise, we applied two filter functions in the Arduino IDE software's source code. The filter functions of an exponential smoothing filter (Oppenheim & Schaffer, 1975; Martinsen, 2017) and a moving average filter (Smith, 1997) are shown in Equations (1) and (2), respectively.

$$y_n = \omega \times x_n + (1 - \omega) \times y_{n-1} \quad (1)$$

where y_n is the output response of the filter at time n . x_n is the new input value at time n . y_{n-1} is the previous output value of the filter. ω is a smoothing factor in the range (0,1). The smoothing level depends on the smoothing factor ω . When the factor was high at 0.9, the level of smoothing was low, and vice versa.

$$y[i] = \frac{1}{m} \sum_{j=0}^{M-1} x[i+j] \quad (2)$$

where $x[]$ is the input data, $y[]$ is the output data, and M is the number of points used in the moving average (Smith, 1997).

In Fig. 3(b), the continuous sharp noise in the signal response of sensor A was reduced using an exponential smoothing filter and further improved with a combination of the two filters— exponential smoothing filter and moving average filter. For sensor B (Fig. 3(c)), there was sharp periodical noise in the response, and the combination of the same two filters removed all noise. To achieve a highly smooth signal, the weighting factor applied to the exponential smoothing filter was 0.1.

Fig. 4 shows the change in electric signal with the increase in the

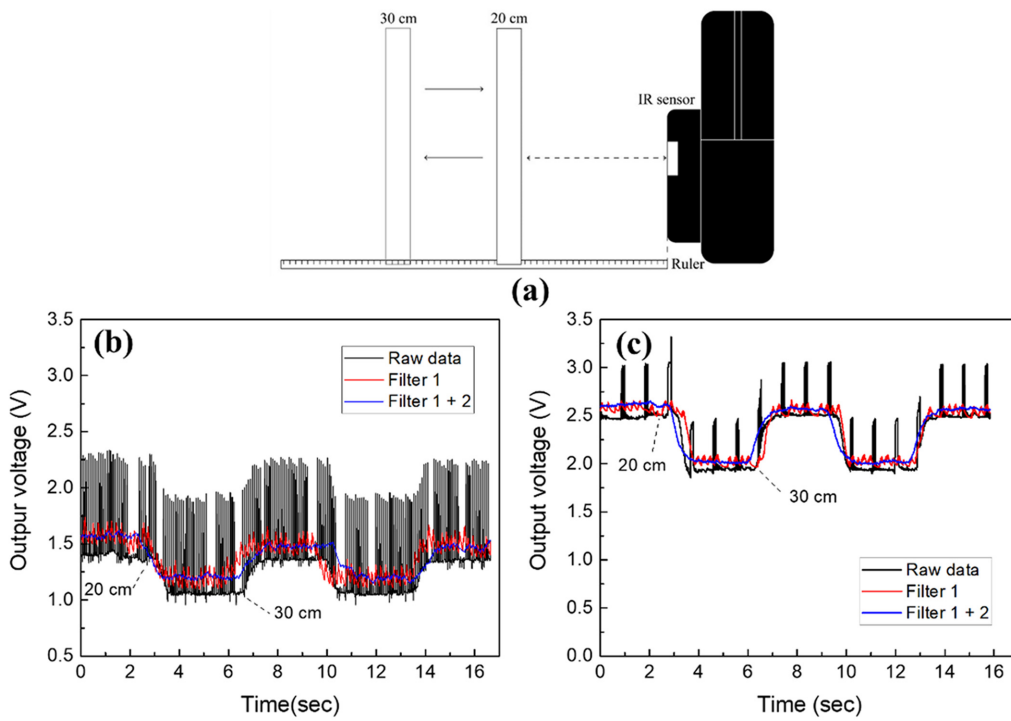

Fig. 3. (a) Schematic diagram of a process of IR sensor experiment, (b) electrical signal with the sensor A (GP2Y0A21YK0F), and (c) electrical signal with the sensor B (GP2Y0A02YK0F).

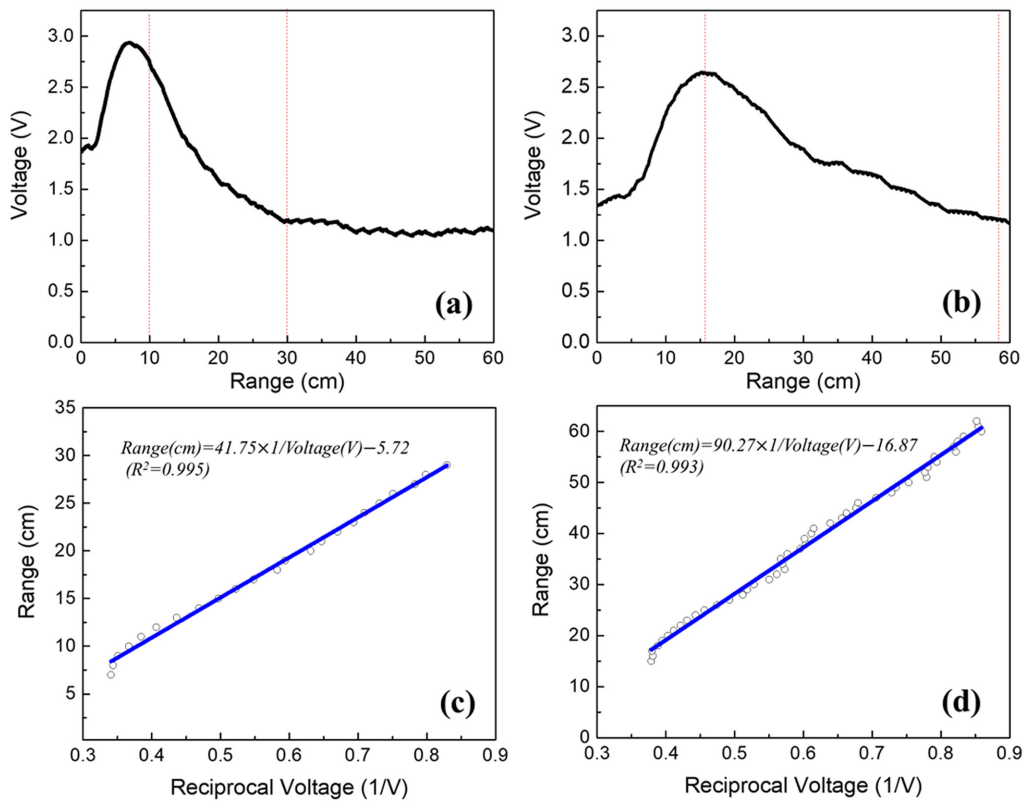

Fig. 4. Change of output voltage in accordance with the range for (a) sensor A and (b) sensor B, and distance calculated according to the output voltage for (c) sensor A and (d) sensor B.

distance for sensors A and B. As shown in Fig. 4(a), the usable range of sensor A was approximately measured from 10 to 30 cm, with high sensitivity at close range, but low sensitivity at far range. On the other hand, the usable range of sensor B was wider than that of sensor A, from 15 to 60 (Fig. 4(b)). To obtain the detection distance in centimeters experimentally, we extracted the useable range data and plotted the detection range versus the reciprocal output voltage. Then, we can fit the first-order fitting line of the blue line shown in Fig. 4(c) and (d) for the calculation of the target distance. In our development of the wearable detection system, sensor B is more applicable due to its wide detection range.

4.2. Electronic circuit design and coding

Fig. 5(a) shows the circuit diagram with the input and output

devices and power source. Fig. 5(b) indicates the circuit schematics design. we connected the proximity sensor to an analog input pin, A2, and two vibration motors to an output pin 7, and the array of 18 LEDs to an output pin 2. Furthermore, we used a boost module for compatibility between the main board and the 6 V batteries. Through the proximity sensor, the distance data was taken as an analog value and transmitted to the Arduino board, and an array of LEDs and two vibration motors were switched on when someone approached the user carrying the smart backpack within 45 cm range.

Fig. 6 illustrates the Arduino IDE (Integrated Development Environment) software's source code for the programming system. In part (1), we set the variables 'sensorValue' and 'filteredValue' for the calculation; we set the initial value for the filter weight and assigned the in-out and output device pin numbers to the variables.

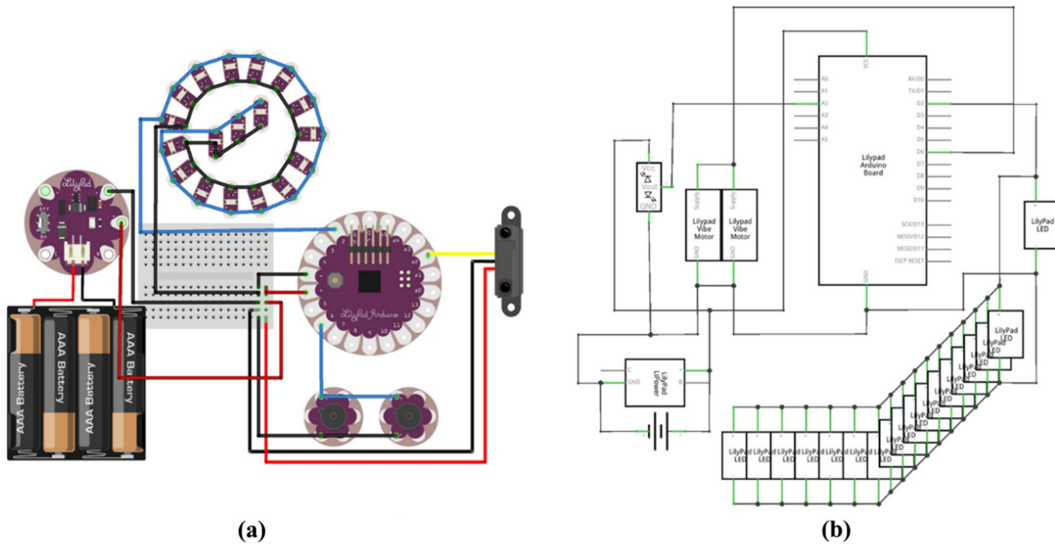

Fig. 5. The smart backpack system: (a) circuit diagram, (b) schematic design.

```

1 #define SIZE 5
2 float distance = 0;
3 float sensorValue;
4 float filteredValue;
5 float sensitivity = 0.1;
6 int Led1=11;
7 int Mot=13;
8 int buffer[SIZE];
9 float sum;
10
11 void setup() {
12   Serial.begin(9600);
13   pinMode(11, OUTPUT);
14   pinMode(13, OUTPUT);
15   pinMode(A3, INPUT);
16 }
17
18 void loop() {
19   sensorValue = map(analogRead(A3), 0, 1023, 0, 5000);
20   filteredValue = filteredValue * (1-sensitivity)
21   + sensorValue * sensitivity;
22
23   sum-=buffer[0];
24   for(int i =0; i<SIZE-1; i++){
25     buffer[i]=buffer[i+1];
26   }
27   buffer[SIZE-1]=filteredValue;
28   sum+=buffer[SIZE-1];
29   filteredValue=sum/SIZE+2;
30
31   distance = 90.27 * pow(filteredValue/1000,-1) - 16.87;
32
33   if(distance <45){
34     digitalWrite(Led1, HIGH);
35     digitalWrite(Mot, HIGH);
36   }
37   else{
38     digitalWrite(Led1, LOW);
39     digitalWrite(Mot, LOW);
40   }
41   delay(10);
42 }

```

Fig. 6. System programming.

Part (2) notifies the beginning of serial communication and then assigns each pin number to the output or input. In part (3), we applied two filter functions to the initial output data to remove the noise. Part (4) is the trendline equation for converting an output voltage into a detection range. The converted range (cm) was assigned to be stored in the 'distance' variable. Part (5) is a conditional statement of the detection range. The system was designed so that if the distance of the approaching people was within 45 cm, then an array of LEDs and vibration motors would be turned on else, they will remain turned off.

4.3. Smart Backpack System Design

Fig. 7 shows a schematic of the smart backpack detection system. The proximity sensor (GP2Y0A02YK0F) (2) was placed in the pocket of the backpack (8), as shown in Fig. 7(a). We attached a digitally printed warning message (3) to the upper part of the backpack as an additional outer layer. On the inner layer, the array of LEDs (7) was stitched with conductive yarn and aligned with the holes on the warning sign on the outer layer, as shown in Fig. 7(b). The main circuit system, which includes the microcontroller board (4), boost module (5), and batteries (6), was placed inside the

backpack. The connecting wire and the circuit system are secured in the fabric tape and covering. The two vibration motors were attached to the inner part of the right backpack strap for close contact with the wearer (Fig. 7(c)). Figure 7(d) shows the prototype of the smart backpack system, which integrates the input and output devices with the circuit.

Fig. 8(a) shows the warning message design used for the system. We digitally printed (GTX-422, Brother, Nagoya, Japan) the message on the canvas fabric. It has 18 holes on a red circle of 1 mm in diameter at 1 cm intervals for the LEDs' array, which was made using a laser cutter (STORM 6040, Bugwang GTC, Korea) (Fig. 8(b)). The fabric with the printed warning message was used as the outer layer of the backpack. Figure 8(c) shows the warning sign of

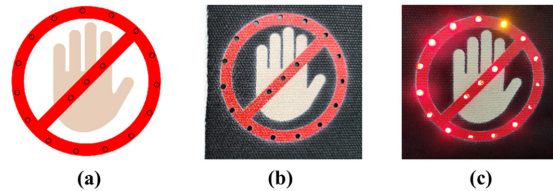

Fig. 8. Illustration for the alarm system: (a) illustration for alarm, (b) after laser cutting, (c) when LEDs are operational.



Fig. 7. Schematic illustrations: (a) front view, (b) inner parts, (c) vibration motors, and (d) prototype of the smart backpack system.



Fig. 9. Photograph of operated smart backpack system with a person within 45 cm range.

the assembly with outer and inner layers when switched on. The advantages of printing on fabric are washability, durability, and interconnectivity with fabric-based products. In addition, it could contribute to providing a customized design.

We demonstrated a smart backpack system, as shown in Fig. 9. When someone approaches the wearer within 45 cm range, two vibration motors and an array of LEDs are turned on to warn both the user and approaching people.

5. Conclusion

This study discusses the development of a backpack-based wearable detection system that can provide a warning using vibration motors and LEDs. To improve the detection accuracy, we applied a combination of the two filters—the exponential smoothing filter and the moving average filter. Experimentally, we obtained the calculation formula of the detection distance. This detection system would help the wearer recognize people or objects approaching from behind through visual and tactile notifications. In future work, we would evaluate the preferences, experiences, and expectations of users with disabilities to improve the user requirements of accessibility and usability of the system. Moreover, the electronics, including the main board and LEDs, are integrated into the inner layer of the backpack. Therefore, technically, the current design is impossible to wash. Therefore, we must consider a detachable modular design for electronics for easy maintenance. If this backpack is commercialized, we expect that it could contribute to the safety of general users and those with hearing loss and/or visual impairments. This could also help prevent pedestrian accidents. Therefore, it is worth proceeding with additional studies to develop a more effective detection system for the future.

Acknowledgements

This work was supported by a National Research Foundation of

Korea (NRF) grant funded by the Korean Government (NRF-2022R1A2C2010760).

References

- Alkhalifa, S., & Al-Razgan, M. (2018). Enssat - Wearable technology application for the deaf and hard of hearing. *Multimedia Tools and Applications*, 77(17), 22007-22031. doi:10.1007/s11042-018-5860-5
- Awolusi, I., Marks, E., & Hallowell, M. (2018). Wearable technology for personalized construction safety monitoring and trending - Review of applicable devices. *Automation in construction*, 85, 96-106. doi:10.1016/j.autcon.2017.10.010
- Cho, G. S., Yang, Y. J., & Sung, M. S. (2008). Development and its present status of bio-monitoring smart clothing and e-textiles. *Fashion & Textile Research Journal*, 10(1), 1-10.
- Choi, S. U., Lee, G. H., Kim, W. J., Lee, B. J., Chong, Y. M., & Cho, D. U. (2016). Development of ultrasonic sensors detecting LED by utilizing Arduino. *Proceedings of Symposium of the Korean Institute of communications and Information Sciences*, pp. 443-444.
- Ercan, S. U. & Mohammed, M. S. (2020). Distance measurement and object detection system based on ultrasonic sensor and Xbee. *Duzce University Journal of Science & Technology*, 8(2), 1706-1719. doi:10.29130/dubited.634256
- Haghi, M., Thurow, K., & Stoll, R. (2017). Wearable devices in medical internet of things - Scientific research and commercially available devices. *Healthcare Informatics Research*, 23(1), 4-15. doi:10.4258/hir.2017.23.1.4
- Jeon, A. G., Jeong, D., & Lee, S. H. (2019). Development of wearable device for hearing impaired people using Arduino. *International Journal of Advanced Smart Convergence*, 8(4), 214-220. doi: 10.7236/IJASC.2019.8.4.214
- Ko, J. Y. (2017). Smart safety hat for elderly pedestrians. *Journal of Korea Multimedia Society*, 20(8), 1387-1394. doi:10.9717/kmms.2017.20.8.1387
- Ko, Y. J., & Kim, S. H. (2020). Arduino-based smart portable appliance for the visually impaired. In *Proceedings of the Korea Information Processing Society Conference, Korea*, pp.1074-1076 doi:10.3745/PKIPS.y2020m11a.1074
- Kratz, S. & Rohs, M. (2009). Hoverflow - Exploring around-device interaction with IR distance sensors. In *Proceedings of the 11th*

- International Conference on Human-Computer Interaction with Mobile Devices and Services, Germany*, pp.1-4. doi:10.1145/1613858.1613912
- Lee, S. M., & Lee, D. (2020). Healthcare wearable devices - An analysis of key factors for continuous use intention. *Service Business*, 14(4), 503-531. doi:10.1007/s11628-020-00428-3
- Martinsen, P. (2017). Three methods to filter noisy Arduino measurements. *Megunolink*. Retrieved July 27, 2022, from <https://www.megunolink.com/articles/coding/3-methods-filter-noisy-arduino-measurements/>
- McIntosh, J., Marzo, A., & Fraser, M. (2017). Sensir - Detecting hand gestures with a wearable bracelet using infrared transmission and reflection. In *Proceedings of the 30th annual ACM symposium on user Interface Software and Technology, Canada*, pp. 593-597. doi:10.1145/3126594.3126604
- Oppenheim, A., & Schaffer, R. (1975). *Digital signal processing*. Englewood Cliffs, NJ: Prentice-Hall,
- Park, J. Y., Ahn, C. G., Kim, L. H., Ha, S. D., & Park, S. H. (2006). Development of a wearable computer interface for aurally impaired persons. *Proceeding of Symposium of the HCI Society of Korea, Korea*, pp. 57-62.
- Park, S. S., Park, H. G., Park, S. C., Jeon, M. P., & Lee, B. J. (2019). Child-to-school vehicle safety accident prevention system utilizing video and PIR Sensor. *The Journal of The Korea Institute of Electronic Communication Sciences*, 14(6), 1019-1024. doi:10.13067/JKIECS.2019.14.6.1019
- Sim, J., Seo, I. S., Lee, J. G., Jang, H. K., & Lee, H. Y. (2019). Sensing fall detection using wearable smart belt for elderly. *Communications of the Korean Institute of Information Scientists and Engineer, Korea*, pp.1327-1329.
- Smith, S.W. (1997). *The scientist & engineer's guide to digital signal processing*. San Diego: California Technical Pub.
- Sohn, S. Y., Woo, H. J., & Cho, D. S. (2017). An illegal parking management system based on the proximity sensor. In *Proceeding of Korean Institute of Information Scientists and Engineers, Korea*, pp. 1833-1835.
- Song, H. Y., Kim, J. E., & Kim, T. N. (2020). Artificial intelligence and health communication. *Journal of Communication Research*, 57(3), 196-238. doi:10.22174/jcr.2020.57.3.196
- Taghipour, J. (2017). *The effect of filtering on proximity sensors*. Unpublished master's thesis, California State Polytechnic University, Pomona, USA.

Received August 5, 2022; 1st Revised August 19, 2022;
2nd Revised September 6, 2022; Accepted September 16 2022)